

DESIGNED FOR USE WITH	.085 S.R.
CABLE ENTRY DIAMETER MINIMUM	
HOUSING	.089
CONTACT	.0214

REVISIONS			
REV	DESCRIPTION	DATE	APPROVED
03 <sub>0</sub>	REVISED	7/1/97	PCW 7/1/97

NOTES:

- 1. CAPTURED CENTER CONTACT

.XXX = in  
XX.X = mm (REF)

COMPONENT	MATERIAL	FINISH
HOUSING, OUTER MOUNTING NUT WASHER	STAINLESS STEEL PER ASTM-A484 AND ASTM-A582, TYPE 303	PASSIVATE PER QQ-P-35
RETAINING RING	STAINLESS STEEL	PASSIVATE PER QQ-P-35
HOUSING, INNER	STAINLESS STEEL PER ASTM-A484 AND ASTM-A582, TYPE 303	GOLD PLATE PER MIL-G-45204
DIELECTRIC	TFE FLUOROCARBON PER ASTM-D-1457	N/A
CENTER CONTACT	BERYLLIUM COPPER PER ASTM-B-196 OR ASTM-B-197, ALLOY C17300, CONDITION H	GOLD PLATE PER MIL-G-45204
CONTACT SLEEVE	BERYLLIUM COPPER PER ASTM-B-196, ALLOY C17300, CONDITION H	GOLD PLATE PER MIL-G-45204
CONTACT RING	BERYLLIUM COPPER PER ASTM-B-194, ALLOY C17200, CONDITION H	GOLD PLATE PER MIL-G-45204
LOCKWASHER	CARBON STEEL 1050	NICKEL PLATE PER QQ-N-290
SPRING	MUSIC WIRE	NICKEL PLATE PER QQ-N-290

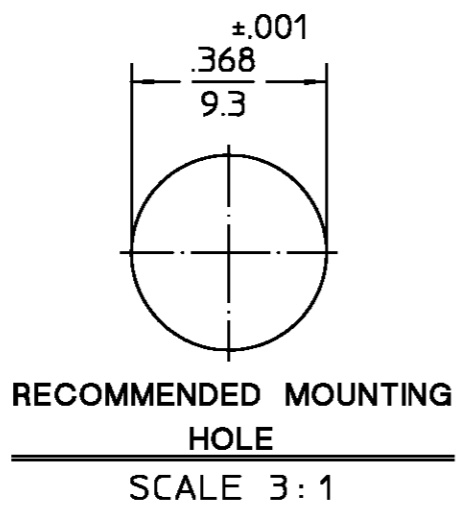

UNLESS OTHERWISE SPECIFIED DIMENSIONS ARE IN INCHES  
FRAC. DEC. ANGLES  
± 1/64 ±.005 ± 1°

DRAWN BY J.B. DATE 9/10/87  
CHECKED BY M.H./M. 9/16/87  
APPD BY B.A.R. 9/16/87

AMP Incorporated  
140 Fourth Avenue  
Waltham, MA 02451-7599

These drawings and specifications are the property of M/A COM Interconnect Div. and shall not be reproduced or copied or used in whole or in part as the basis for the manufacture or sale of item(s) without written permission.

USE ASSY PROCEDURE  
408-04596  
NO. A.P. (45-047)

TITLE OSP FLOATING PANEL FEEDTHRU CABLE JACK DIRECT SOLDER ATTACHMENT  
SIZE B CODE IDENT NO. 26805 4522-7985-02 REV 03<sub>0</sub>  
SCALE 6:1 SHEET 1 OF 1